

CIRCULAR CAV AND VAV

AIR VOLUME CONTROL TERMINALS

NA / NB SERIES



HC GROEP
HC BARCOL-AIR | AIR DISTRIBUTION

Description	Page
Type designation	1
Technical data	
- General	2
- Specification	3
- Installation instruction	3
Model overview / dimensions	4 - 5
Sound data NAOB... / NBOB...	6 - 7
Sound data NAOC... / NBOC...	8 - 9
Sound data NAOG... / NBOG... / NAON... / NBON...	10 - 11
Sound data NAOJ... / NBOJ... / NAOQ... / NBOQ...	12 - 13

Composition type designation:

N - B - O - N - E - O - B

N Position 1: **Product group**

N = air volume control terminals

B Position 2: **Function**

A = single wall, circular volume control terminal
B = double wall, circular volume control terminal
1 = non standard, specify separately

O Position 3: **Controls (manufacturer)**

O = without controls
For controls, contact our sales staff

Q Position 4: **Outlet**

A = rectangular outlet
B = circular outlet
C = 4 circular outlets ('Octopus')
G = rectangular outlet and provision for integral hot water reheat coil
J = 4 circular outlets and provision for integral hot water reheat coil
N = rectangular outlet and provision for integral electric reheat coil
Q = 4 circular outlets and provision for integral electric reheat coil
1 = non standard, specify separately

E Position 5: **Reheat coil**

O = without reheat coil
A = 1-row hot water reheat coil
B = 2-row hot water reheat coil
D = 4-row hot water reheat coil
E = 1-stage 230VAC/1-phase electric reheat coil
F = 2-stage 230VAC/1-phase electric reheat coil
G = 3-stage 230VAC/1-phase electric reheat coil
H = 1-stage 400VAC/3-phase electric reheat coil
J = 2-stage 400VAC/3-phase electric reheat coil
1 = non standard, specify separately

O Position 6: **Controls (type & function)**

O = without controls
For controls, contact our sales staff

B Position 7: **Sensor**

O = not applicable
B = Flo-Cross®, 2 x 12 point averaging and signal amplifying air flow sensor (standard)
1 = non standard, specify separately

Ordering example:

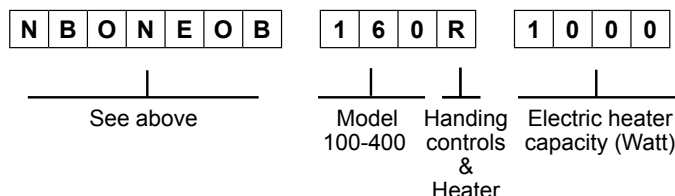

Ordering codes "Specials"

N..1... - 3010 = 4 balancing dampers in 'Octopus' outlet
N..1... - 3006 = 'Octopus' with 6 outlets instead of 4
N..1... - 3016 = 'Octopus' with 6 outlets incl. balancing dampers
N..1... - FL = Flange connection 30 mm for rectangular outlet
N..1...-SS316L= Unit made of stainless steel

Ordering information:

Standard terminals:

- quantity of terminals
- complete 7 digit code
- terminal size or model
- air volume setting (V_{max} , V_{min} etc)
- control handing (standard right side)
- if applicable, electric reheat coil capacity
- supply or return air

Non standard terminals:

- for non standard terminals a full description and/or drawing are requested

Circular VAV and CAV air volume control terminals

Technical data
Single wall (NA.....)
Double wall (NB.....)

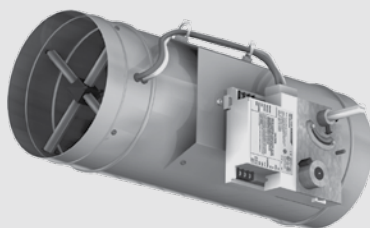

Application

Types NA and NB are circular pressure-independent VAV and CAV air volume control terminals. The terminals are designed particularly for systems with space and installation restrictions and for the accurate measurement and control of air volumes courtesy of the patented airflow sensor type Flo-Cross®.

In CAV application, the terminals maintain the required constant airflow independent to the inlet static pressure.

In VAV application, the terminals control the air volume to the room, depending on the cooling load required thus saving energy consumption in both cooling and heating applications.

Alternatively VAV terminals are ideal to be used for CO₂ control. Dependent of the indoor air quality, always the correct amount of fresh air will be supplied to the room. Of course the primary air handling system need to be suitable for this.

The VAV or CAV terminals can be used either for supply or return air applications in new or refurbishment projects. The terminals do have a single wall (NA) or double wall (NB) construction and can be delivered with a distribution plenum and a built-in hot water or electric reheat coil.

Features:

- Pressure independent control functions.
- Volume control range 100% down to 10%.
- Low pressure loss over the terminal.
- Single or double wall construction.
- Factory fitted distribution plenum with built-in hot water or electric reheat coil.
- Oval shaped damper blade for linear control characteristics.
- Low leakage damper, less than 2% of V_{nom} at 750 Pa.
- Low noise production.
- Suitable for all control functions (VAV, CAV, shut-off, etc.) to maximise system energy savings.
- Flo-Cross® 2 x 12 points averaging and signal amplifying airflow sensor, better than 2,5% accuracy even with irregular duct approach.
- Maintenance free.

Technical information

Casing:

Single or double wall, air-tight construction made of galvanized sheet steel (non spiral), casing leakage rate to Class II VDI 3803 or DIN 24 194 part 2. Duct-sleeve connections at the in- and outlet are suitable for DIN 24 145 or DIN 24 146 connections. In case of double wall construction 25 mm insulation material is used, completely enclosed by the double wall construction. Optionally the unit can be made of stainless steel 316L.

Insulation:

The terminal is supplied with 25 mm thermal and acoustical insulation (30 kg/m³) complying to: NFPA90A and 90B surface burning characteristics, BS476 part 6 and 7 fire propagation, UL 181 class 0 surface spread of flame and UL 94 HF1 flamability.

Damper:

Damper blade: made of steel (SS316L optional), sandwich construction of twin blade and neoprene gasket with low leakage according to DIN 1946, part 4.

Damper shaft: aluminium (SS316L optional), ø12 mm with self lubricating Nylon bearings.

Flo-Cross®:

Extruded aluminium construction with nylon core + feet.

Distribution plenum:

Made of galvanized sheet steel with 13 mm internal isolation. Plenum with standard rectangular or multiple (4 x circular) outlet construction. Optional single, double, triple or six circular outlets are possible. Outlet spigots are made of flame retardant polymer and optionally can be provided with volume control dampers made of galvanized sheet steel.

Reheat coil:

Choice of 1-, 2- or 4-row hot water reheat coil or electric reheat coil (230VAC/1-phase or 400VAC/3-phase).

More detailed technical information can be found in the separate NO documentation.

Controls:

Suitable for use with pneumatic, analogue electronic or DDC controllers. Controls can be factory fitted, wired and calibrated. Controls enclosure (galvanized sheet steel) can be provided optionally.

Delivery format

Delivery format:

- The VAV or CAV terminal will be supplied as a single mounting assembly. Optional ordered distribution plenum, reheat coil and/or controls are factory fitted, wired and calibrated. The on site delivered terminal can directly be installed and commissioned.
- Controls location and hot water or electric connections are as a standard fitted on the right hand side of the terminal when looking in the direction of the airflow.
- On request, the terminal can be delivered with connections on the left hand side.
- When terminals are ordered with controls, these will be factory fitted, wired and calibrated upon request.
- For terminals ordered with 'free-issue' third party controls, wiring diagrams and mounting instructions must be provided.

Circular VAV and CAV air volume control terminals

Technical data
Single wall (NA.....)
Double wall (NB.....)

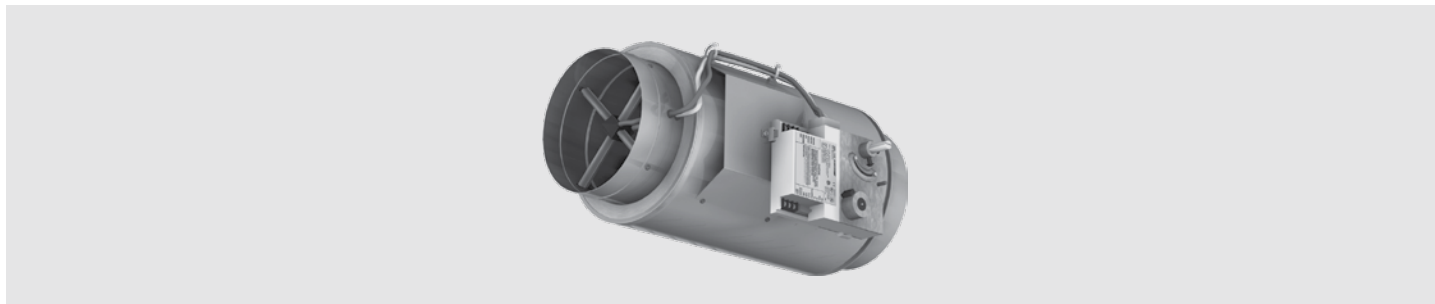

Specify as:

Example:

Supply and install, variable air volume terminals, double-wall construction with distribution plenum with 4 circular outlets, constructed from galvanized sheet steel. The casing leakage rate shall be classified according to class II, VDI 3803/DIN 24 194 and the duct-sleeve connections shall be suitable for DIN 24 145 or DIN 24 146 respectively. The VAV terminals shall have a low leakage, sandwich construction and oval shaped damper blade with neoprene gasket and an aluminium damper shaft with self lubricating Nylon bearings.

A centre averaging airflow sensor with at least 2 x 12 test points and amplified signal, type Flo-Cross® shall control the airflow with an accuracy better than 2.5 %. The terminals shall be supplied with 1-row hot water reheat coil.

The controller shall be I/A Series, DDC controller:
LonMark® compatible, type MNL-V2RVx or
BACnet® compatible, type MNB-V2.

Controls must be factory fitted, wired and calibrated according to the following requirements:

Maximum air volume 250 l/s
Minimum air volume 60 l/s
Minimum air volume 120 l/s (in case of reheat)
Terminal size 200 mm
Max. pressure loss 38 Pa
Max. discharge sound index < NC30 (@250Pa Δp)
Max. radiated sound index < NC30 (@250Pa Δp)

Ordering example: type – model – handing
= NBOJA0B – 200R

Manufacturer: HC Barcol-Air

Installation Instructions:

The HC Barcol-Air VAV terminals shall be installed using at least two support brackets (DIN-rail or L-profile), with anti-vibration rubber under the terminal. Each of these brackets shall be fixed with two threaded rods to the ceiling slab above.

This installation method:

- 1 Shall prevent the body of the VAV terminal from high mechanical tension, which could damage the construction and performance of the terminal.
- 2 Shall prevent torsion on the VAV terminals, which could cause malfunction of the damper blades.
- 3 Provides some flexibility to the final location of the VAV terminals.
- 4 Use at least 1x diameter straight duct length before the VAV inlet.

- 5 Additional manual volume control dampers (VCD's) before the inlet are not required / recommended!!
6. All connections shall be thermally isolated.
7. Pressure sensing tubes of Flo-Cross® airflow sensor shall not be "kinked" or otherwise obstructed by the external duct insulation.

Installation of circular VAV terminals can be done in a similar way, with the only assumption that two circular support brackets with anti-vibration rubber (installation clamps) instead of DIN-rail or L-profile shall be used. To prevent the VAV terminal from rotation, we recommend to use a complete clamp (support + top bracket), so that the terminal is 'clammed' in between.

Optional 4 x Mupro fixing hooks can be used (see drawing).

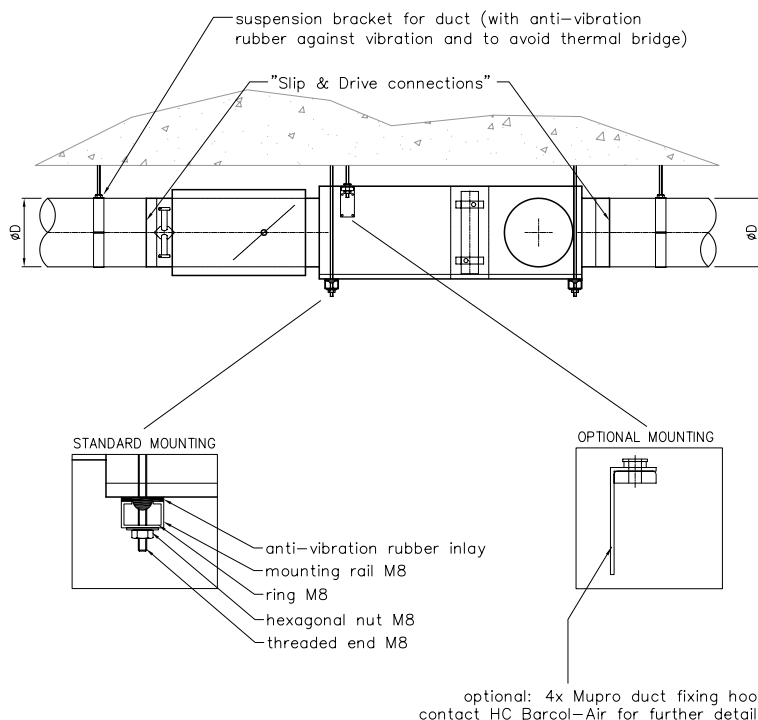

Circular VAV and CAV air volume control terminals

Model overview Single wall - type NA.....

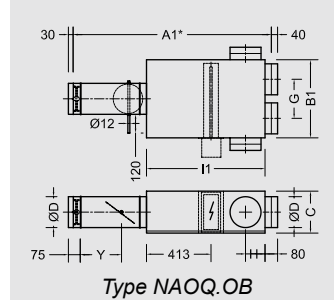
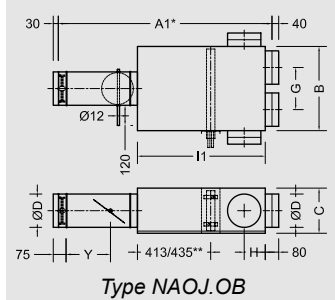
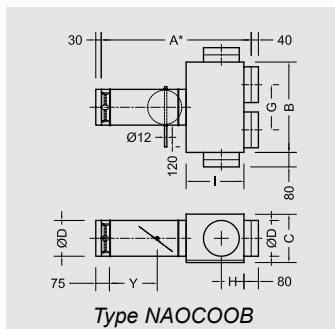
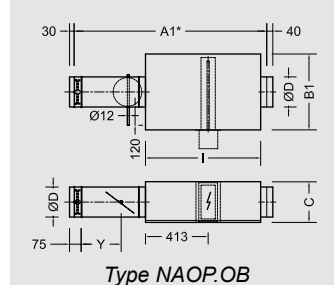
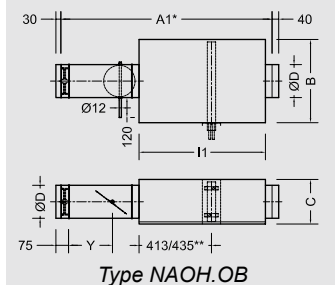
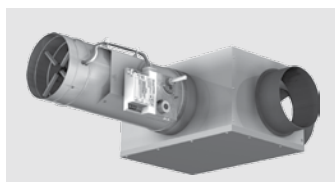
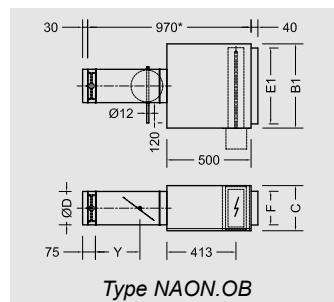
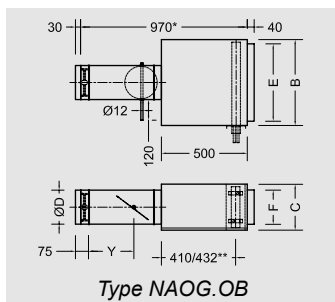
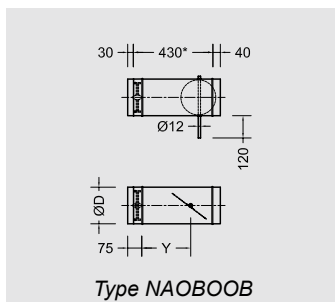
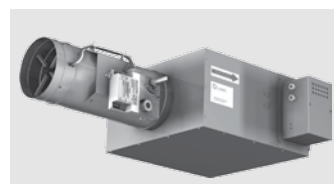
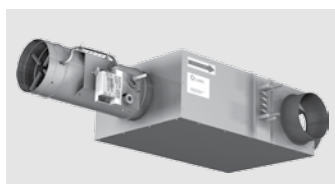
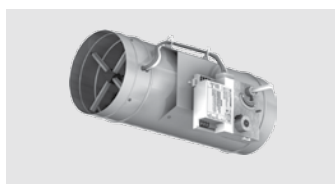

Dimensions NA terminals

Model	100	125	160	200	250	315	355	400
A*	780	780	780	830	880	930	990	1030
A1*	1230	1230	1230	1280	1330	1380	1440	1480
B	330	330	400	500	600	740	820	910
B1	330	330	400	400	600	600	600	600
C	228	228	248	268	318	408	408	458
ØD	98	123	158	198	248	313	353	398
E	275	275	350	450	550	690	770	850
E1	275	275	350	350	550	550	550	550
F	170	170	175	200	250	330	330	380
G	180	180	215	255	305	370	410	455
H	125	125	125	125	175	200	250	250
I	270	270	270	320	370	420	520	520
I1	720	720	720	770	820	870	970	970
Y	310	310	310	300	285	260	245	235

Other dimensions are available upon request.

Kv values

Model	100	125	160	200	250	315	355	400
Kv (l/s / Pa)	5,5	8,5	15,0	24,9	35,4	58,9	74,3	92,6

All dimensions in mm.

* = Installed length.

** = Size varies with a 1-1/2-row or 4-row hot water reheat coil.

$$\text{Flow} = K_v \times \sqrt{\Delta P_{fc}}$$

ΔP_{fc} = Flo-Cross® signal

If $\Delta P_{fc} = 30 \text{ Pa}$ and VAV size = 160

$$\text{Flow} = 15,0 \times \sqrt{30} = 82 \text{ l/s}$$

Circular VAV and CAV air volume control terminals

Model overview Double wall - type NB.....

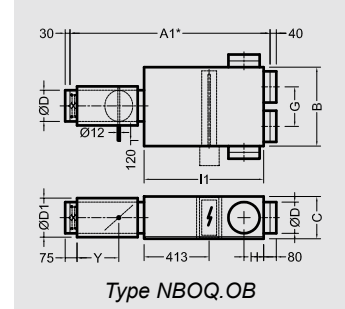
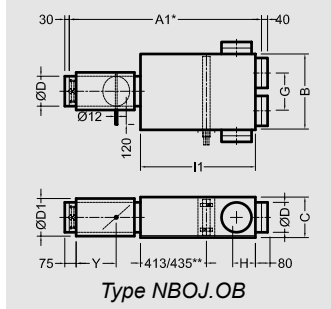
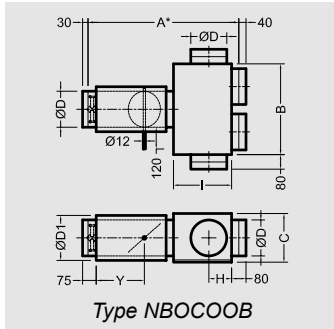
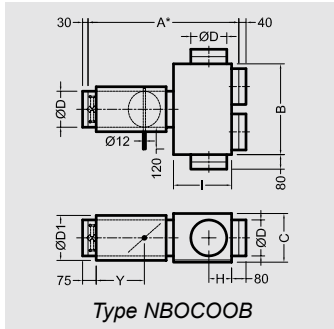
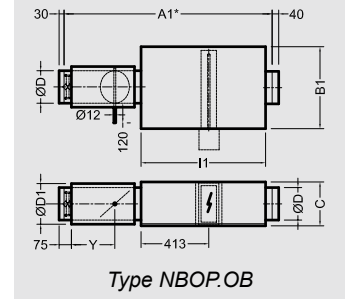
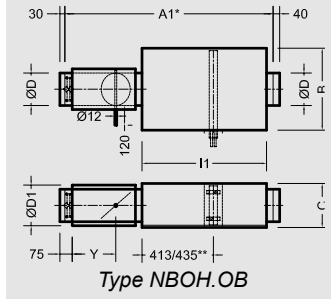
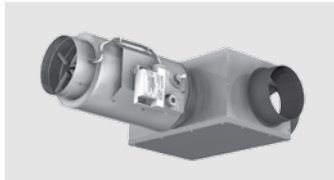
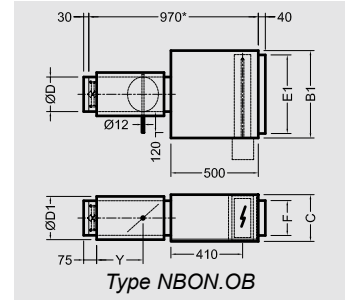
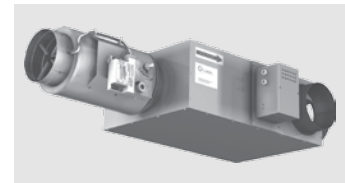
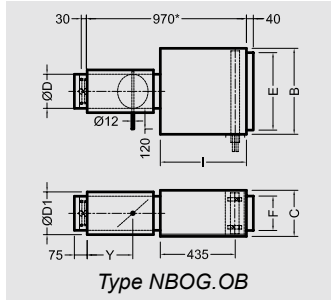
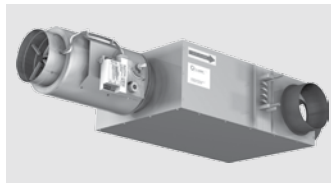
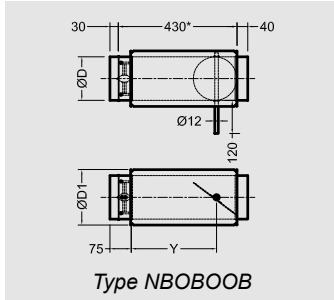
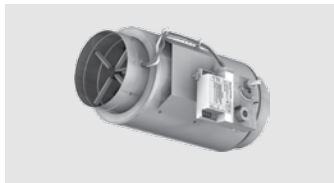

Dimensions NB terminals

Model	100	125	160	200	250	315	355	400
A*	780	780	780	830	880	930	990	1030
A1**	1230	1230	1230	1280	1330	1380	1440	1480
B	330	330	400	500	600	740	820	910
B1	330	330	400	400	600	600	600	600
C	228	228	248	268	318	408	408	458
ØD	98	123	158	198	248	313	353	398
ØD1	150	180	200	250	300	355	400	450
E	275	275	350	450	550	690	770	850
E1	275	275	350	350	550	550	550	550
F	170	170	175	200	250	330	330	380
G	180	180	215	255	305	370	410	455
H	125	125	125	125	175	200	250	250
I	270	270	270	320	370	420	520	520
I1	720	720	720	770	820	870	970	970
Y	310	310	310	300	285	260	245	235

All dimensions in mm.

* = Installed length.

** = Size varies with a 1-1/2-row or 4-row hot water reheat coil.

Other dimensions are available upon request.

Kv values

Model	100	125	160	200	250	315	355	400
Kv (l/s / Pa)	5,5	8,5	15,0	24,9	35,4	58,9	74,3	92,6

$$\text{Flow} = K_v \times \sqrt{\Delta P_{fc}}$$

ΔP_{fc} = Flo-Cross® signal

If $\Delta P_{fc} = 30 \text{ Pa}$ and VAV size = 160

Flow = $15,0 \times \sqrt{30} = 82 \text{ l/s}$

