



# AIRFLOW & ZONE CONTROLS

## MR Modulo

### Adjustable Constant Airflow Regulator

PRODUCT  
SPECIFICATIONS  
& TECHNICAL  
DATA



#### GENERAL

The model MR Modulo Adjustable Constant Airflow Regulator is a modulating orifice that automatically regulates airflows in duct systems to constant levels. The passive control element responds to duct pressure and requires no electric or pneumatic sensors or controls.

The MR Modulo compensates for changes in duct pressure caused by thermal stack effect, building pressure, dust-clogged filters, etc. The MR Modulo also provides a quiet, low-cost solution to balancing forced-air systems for heating, air conditioning and ventilation, eliminating the need for on-site balancing. The MR Modulo will regulate airflow in supply, return, or exhaust duct systems. It can be mounted horizontally or vertically, and can be fitted in ductwork and accessories.

The active control element of the MR Modulo is a flexible bulb that inflates and deflates in response to the static pressure difference across the control. This operation regulates the free-area opening through the control, resulting in maintenance of velocity and specific airflow setpoints. Each MR Modulo is designed and produced for control of air in temperatures ranging from 14° to 140°F (-10° to 60°C).

#### CONSTRUCTION

The MR Modulo is constructed of PC / ABS plastic, and it is UL 2043 safety classified and labeled for flame and smoke generation. The assembly is sized to fit inside standard rigid round ducting, as well as fittings such as take-offs, tees, etc. A double-lip airtightness seal around the circumference ensures a tight, no-leak fit.

#### PERFORMANCE

The MR Modulo airflow regulators control airflow accurately to within  $\pm 3$  CFM (5 m<sup>3</sup>/h) for nominal airflow  $\leq 30$  CFM (50 m<sup>3</sup>/h) and  $\pm 10\%$  for nominal airflow  $> 30$  CFM (50 m<sup>3</sup>/h) throughout the target operating pressure range of 0.2 to 1.0 in. w.g. (50 to 250 Pa). Each diameter of MR Modulo regulator is available in multiple factory-calibrated setpoints (see performance curves). Field adjustment of airflow setpoints is achieved by twisting the integral rotating ring to the desired setpoint. No tools are required.

#### INSTALLATION

The MR Modulo will push-fit into circular ducts in close proximity to a take-off or a terminal. Mounting can be horizontal or vertical. The MR Modulo orientation must correspond to the airflow direction indicated on the device.

## MR Modulo Construction

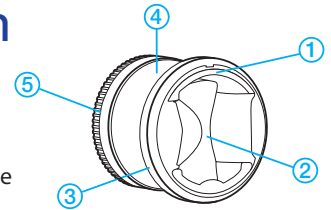

1. Removable clip
2. Regulating silicon membrane
3. Double-lip airtightness seal
4. Housing
5. Rotating airflow adjustment ring

Information indicated directly on the product:

- Flow direction, diameter, operating differential pressure range, part number, and date of manufacture
- Airflow setting range correlation table in CFM and m<sup>3</sup>/h

## Typical Applications

- Supply and exhaust air for offices
- Balancing exhaust and supply airflows in high-rise building duct risers
- Bathroom exhaust in nursing homes, hotels, motels, dormitories, apartment buildings, offices, etc.
- Clean room air supply balancing for ceiling filter modules. Maintains constant airflow, even as filter resistance increases
- Regulation of make-up air
- Balancing supply airflow from packaged roof-top A/C units
- Balancing supply and exhaust of heat recovery ventilation systems
- Regulating outdoor air injection from central supply fan into individual room fan coil units or heat pumps
- Balancing airflows on series-fan-powered terminal unit systems
- Supply air to sleeping quarters in military facilities, etc.

#### MAINTENANCE

The MR Modulo needs no maintenance when used in normal conditions. There is no risk of dust deposits or obstruction because the MR Modulo has no airways subject to clogging. If the intended application includes air heavily loaded with grease or dust, a fitting with an access panel or door, such as that used for flame dampers, should be provided.

#### WARRANTY

Guaranteed for five (5) years, from date of shipment, against all defects in material or workmanship, provided that the material has been installed and used under normal conditions. This warranty is limited to the repair or replacement of the material.

# How the MR Modulo Works

Constant airflow is achieved by the inflating action of the MR Modulo's bulb. At minimum static air pressure, the bulb is deflated and has a shape similar to an hourglass. As the static pressure increases across the bulb, it inflates, thereby reducing the free area around the bulb. At the same time, the higher static pressure increases the air velocity, resulting in **CONSTANT AIRFLOW**. This occurs regardless of pressure differences in the range of 0.2 to 1.0 in. w.g. (50 to 250 Pa). The air velocity in the duct is in the range of 60 to 700 ft/min. (0.3 to 3.5 m/s).

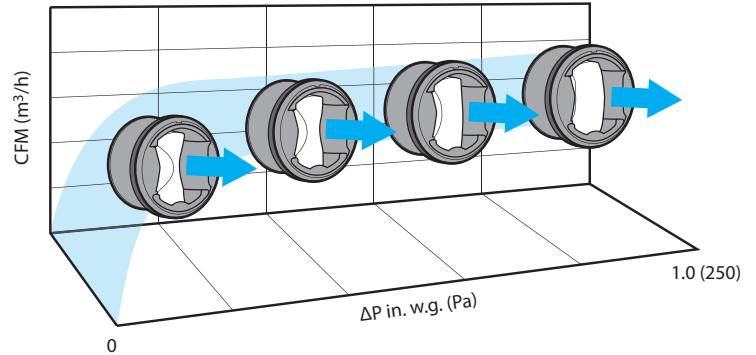

## MR Modulo Dimensions

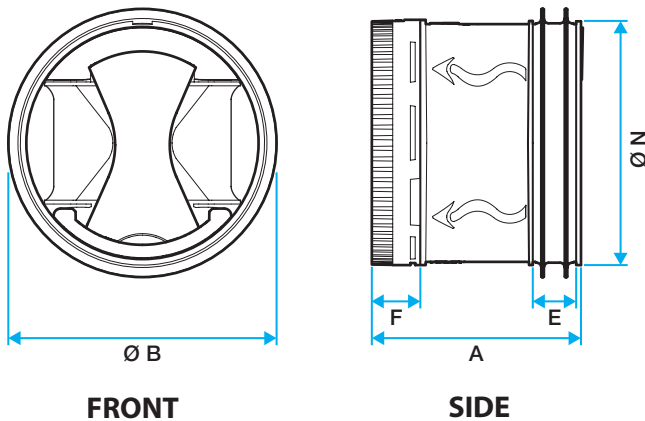

Ø Duct Diameter	ØN	ØB	E	F	A	Weight
4" (100 mm)	3.62" (92 mm)	4.13" (105 mm)	0.55" (14 mm)	0.51" (13 mm)	2.76" (70 mm)	0.26 lbs (0.12 kg)
5" (125 mm) 10-50 CFM	4.57" (116 mm)	5.20" (132 mm)	0.55" (14 mm)	0.51" (13 mm)	2.76" (70 mm)	0.33 lbs (0.15 kg)
5" (125 mm) 60-115 CFM	4.57" (116 mm)	5.20" (132 mm)	0.55" (14 mm)	0.67" (17 mm)	4.33" (110 mm)	0.37 lbs (0.17 kg)
6" (150 mm)	5.79" (147 mm)	6.02" (153 mm)	0.55" (14 mm)	0.75" (19 mm)	4.65" (118 mm)	0.82 lbs (0.37 kg)
8" (200 mm)	7.48" (190 mm)	8.27" (210 mm)	0.79" (20 mm)	0.91" (23 mm)	5.67" (144 mm)	1.31 lbs (0.59 kg)
10" (250 mm)	9.37" (238 mm)	10.32" (262 mm)	0.79" (20 mm)	1.02" (26 mm)	7.05" (179 mm)	2.25 lbs (1.02 kg)

## Typical Specification

Model MR Modulo Adjustable Constant Airflow Regulators by American ALDES Ventilation Corporation, Bradenton, Florida, shall operate solely on duct pressure and require no external power supply. Each regulator shall be capable of being field adjusted to the required airflow setpoint, as indicated on the schedule, by twisting the rotating ring to the corresponding airflow set value. The device shall be rated for use in air temperatures ranging from 14° to 140°F (-10° to 60°C).

Constant Airflow Regulators shall be capable of maintaining constant airflow within ± 3 CFM (5 m³/h) for nominal airflow ≤ 30 CFM (50 m³/h) and ± 10% for nominal airflow > 30 CFM (50 m³/h) throughout the target operating pressure range of 0.2 to 1.0 in. w.g. (50 to 250 Pa) differential pressure. Sound power levels shall not exceed those for each size and CFM rating as scheduled.

Regulators shall be provided as an assembly consisting of a PC/ABS plastic housing and regulating silicon membrane. A rotating adjustment ring shall allow for setting of airflow to calibrated setpoints. No tools shall be needed to set airflow. Each assembly shall be fitted with a double-lip airtightness seal in elastomer. All regulators must be classified per UL 2043 and carry the UL mark indicating compliance.

All MR Modulo Adjustable Constant Airflow Regulators will require no maintenance and must be warranted for a period of no less than five (5) years. MR Modulo Adjustable Constant Airflow Regulators shall be installed in tight ducting systems in accordance with all applicable codes and manufacturer's instructions.

# MR Modulo Airflow Performance Data

Performance charts reflect airflow variation for each size MR Modulo according to the pressure difference between upstream and downstream of the device. The MR Modulo is designed for the differential operating range from 0.2-1.0 in. w.g. (50-250 Pa). Airflow measurements taken at 68°F (20°C) at 1 atmosphere pressure. The MR Modulo regulates within the following nominal airflow tolerances:  $\pm 3$  CFM (5 m<sup>3</sup>/h) for nominal airflow  $\leq 30$  CFM (50 m<sup>3</sup>/h) and  $\pm 10\%$  for nominal airflow  $> 30$  CFM (50 m<sup>3</sup>/h). Sizes are nominal. Product is designed to be inserted into duct of indicated diameter.

## 4" DIAMETER (100 mm) REGULATING ELEMENT

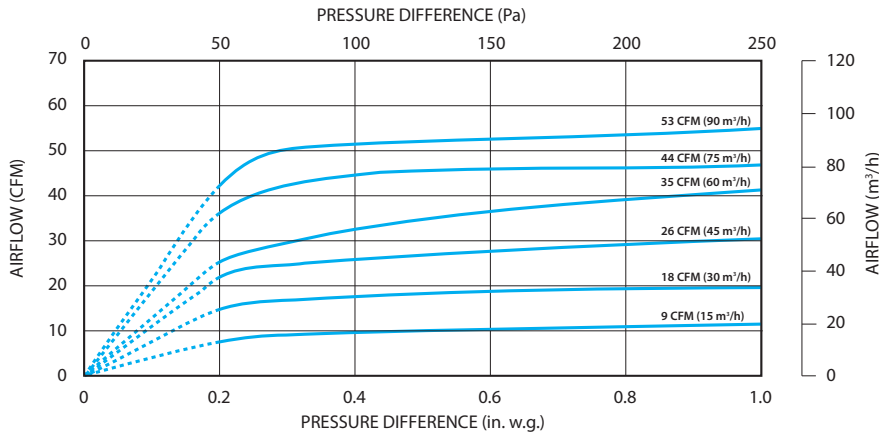

PART NUMBER	AVAILABLE SETPOINTS
11016308	9 CFM (15 m <sup>3</sup> /h)
	12 CFM (20 m <sup>3</sup> /h)
	15 CFM (25 m <sup>3</sup> /h)
	18 CFM (30 m <sup>3</sup> /h)
	21 CFM (35 m <sup>3</sup> /h)
	24 CFM (40 m <sup>3</sup> /h)
	26 CFM (45 m <sup>3</sup> /h)
	32 CFM (55 m <sup>3</sup> /h)
	41 CFM (70 m <sup>3</sup> /h)
	44 CFM (75 m <sup>3</sup> /h)
53 CFM (90 m <sup>3</sup> /h)	

## 5" DIAMETER (125 mm) REGULATING ELEMENT

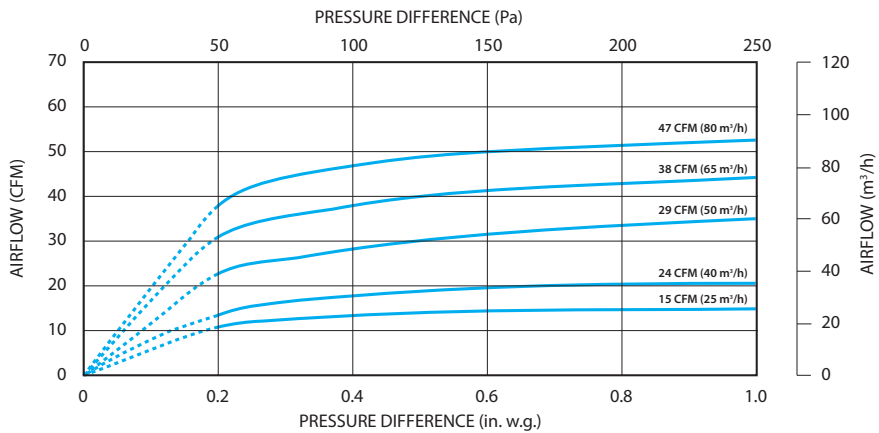

PART NUMBER	AVAILABLE SETPOINTS
11016309	9 CFM (15 m <sup>3</sup> /h)
	15 CFM (25 m <sup>3</sup> /h)
	18 CFM (30 m <sup>3</sup> /h)
	26 CFM (45 m <sup>3</sup> /h)
	29 CFM (50 m <sup>3</sup> /h)
	35 CFM (60 m <sup>3</sup> /h)
	38 CFM (65 m <sup>3</sup> /h)
	41 CFM (70 m <sup>3</sup> /h)
	44 CFM (75 m <sup>3</sup> /h)
	47 CFM (80 m <sup>3</sup> /h)
50 CFM (85 m <sup>3</sup> /h)	

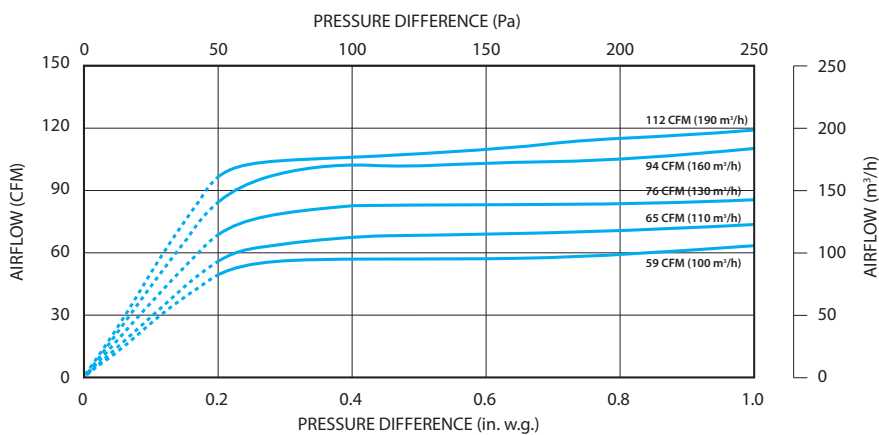

PART NUMBER	AVAILABLE SETPOINTS
11016310	59 CFM (100 m <sup>3</sup> /h)
	65 CFM (110 m <sup>3</sup> /h)
	71 CFM (120 m <sup>3</sup> /h)
	76 CFM (130 m <sup>3</sup> /h)
	82 CFM (140 m <sup>3</sup> /h)
	88 CFM (150 m <sup>3</sup> /h)
	94 CFM (160 m <sup>3</sup> /h)
112 CFM (190 m <sup>3</sup> /h)	

# MR Modulo Airflow Performance Data

Performance charts reflect airflow variation for each size MR Modulo according to the pressure difference between upstream and downstream of the device. The MR Modulo is designed for the differential operating range from 0.2-1.0 in. w.g. (50-250 Pa). Airflow measurements taken at 68°F (20°C) at 1 atmosphere pressure. The MR Modulo regulates within the following nominal airflow tolerances:  $\pm 3$  CFM (5 m<sup>3</sup>/h) for nominal airflow  $\leq 30$  CFM (50 m<sup>3</sup>/h) and  $\pm 10\%$  for nominal airflow  $> 30$  CFM (50 m<sup>3</sup>/h). Sizes are nominal. Product is designed to be inserted into duct of indicated diameter.

## 6" DIAMETER (150 mm) REGULATING ELEMENT

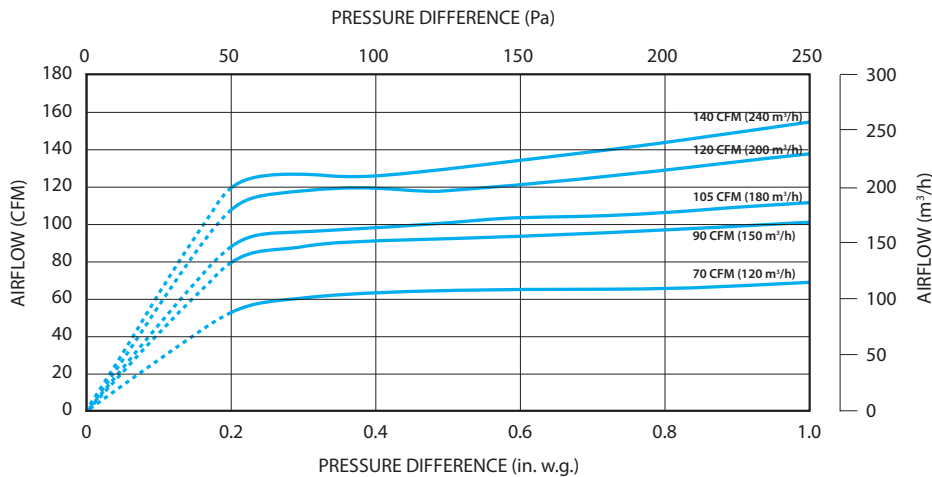

PART NUMBER	AVAILABLE SETPOINTS
11016311	60 CFM (100 m <sup>3</sup> /h)
	65 CFM (110 m <sup>3</sup> /h)
	70 CFM (120 m <sup>3</sup> /h)
	75 CFM (130 m <sup>3</sup> /h)
	80 CFM (140 m <sup>3</sup> /h)
	90 CFM (150 m <sup>3</sup> /h)
	95 CFM (160 m <sup>3</sup> /h)
	100 CFM (170 m <sup>3</sup> /h)
	105 CFM (180 m <sup>3</sup> /h)
	110 CFM (190 m <sup>3</sup> /h)
	120 CFM (200 m <sup>3</sup> /h)
125 CFM (210 m <sup>3</sup> /h)	
140 CFM (240 m <sup>3</sup> /h)	

## 8" DIAMETER (200 mm) REGULATING ELEMENT

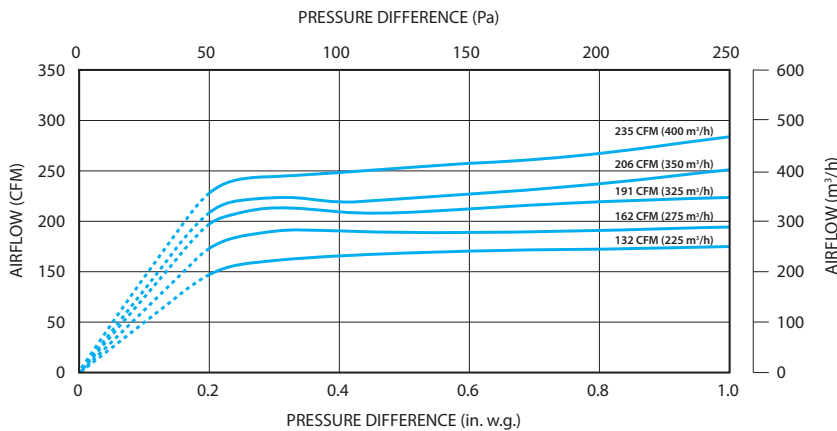

PART NUMBER	AVAILABLE SETPOINTS
11016313	132 CFM (225 m <sup>3</sup> /h)
	147 CFM (250 m <sup>3</sup> /h)
	162 CFM (275 m <sup>3</sup> /h)
	177 CFM (300 m <sup>3</sup> /h)
	191 CFM (325 m <sup>3</sup> /h)
	206 CFM (350 m <sup>3</sup> /h)
	235 CFM (400 m <sup>3</sup> /h)

## 10" DIAMETER (250 mm) REGULATING ELEMENT

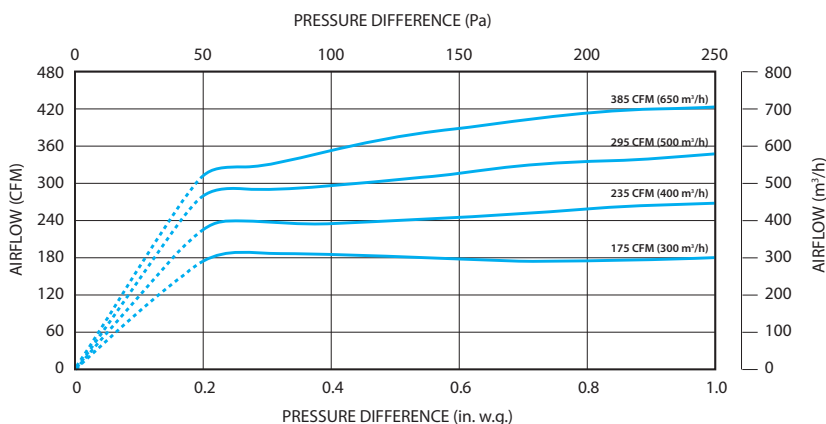

PART NUMBER	AVAILABLE SETPOINTS
11016314	175 CFM (300 m <sup>3</sup> /h)
	205 CFM (350 m <sup>3</sup> /h)
	235 CFM (400 m <sup>3</sup> /h)
	265 CFM (450 m <sup>3</sup> /h)
	295 CFM (500 m <sup>3</sup> /h)
	385 CFM (650 m <sup>3</sup> /h)



# MR Modulo Acoustic Data

Sound power levels of noise (Lw) at duct output. The following tables give the sound power levels of noise (Lw) expressed in decibels per octave (dB/oct) as well as the global sound power levels in dB(A) according to the pressure drop. These sound power levels are results of tests carried out by a Dutch independent laboratory (PEUTZ) and are given at the duct outlet. Measures were carried out in accordance with NF EN ISO 3741 and NF EN ISO 5135 norms, with an MR Modulo fitted into a duct with an upstream and downstream straight length equal to 3 diameters.

Ø6" (150 mm)		Differential Pressure DP in. w.g. (Pa)																																
Airflow		0.2 (50)					0.4 (100)					0.8 (150)					1.0 (200)																	
m <sup>3</sup> /h	CFM	L/s	125 Hz	250 Hz	500 Hz	1000 Hz	2000 Hz	4000 Hz	8000 Hz	Overall Lw (dB(A))	125 Hz	250 Hz	500 Hz	1000 Hz	2000 Hz	4000 Hz	8000 Hz	Overall Lw (dB(A))	125 Hz	250 Hz	500 Hz	1000 Hz	2000 Hz	4000 Hz	8000 Hz	Overall Lw (dB(A))								
110	65	31	31	31	30	24	19	10	12	33	36	37	40	34	31	25	17	40	38	40	44	39	37	32	26	45	39	43	48	44	43	38	33	52
120	70	33	31	31	30	24	19	11	13	32	37	38	40	34	31	25	17	41	39	41	44	40	37	32	26	46	41	44	48	44	43	39	33	53
130	75	36	31	31	30	24	19	11	13	31	38	38	40	35	32	26	18	41	41	42	44	40	38	33	26	46	42	45	49	44	43	39	33	53
140	80	39	31	31	30	25	20	11	13	31	39	39	40	36	32	26	18	41	42	43	45	40	38	33	26	46	44	47	49	45	44	39	33	54
150	90	42	31	31	30	25	20	11	13	31	40	40	40	36	33	26	18	41	43	44	45	41	39	33	26	46	46	48	49	45	44	39	33	55
160	95	44	31	31	30	26	20	11	13	31	42	41	39	37	33	27	19	42	44	45	45	41	39	33	26	47	47	49	50	45	44	40	33	56
170	100	47	31	31	30	26	21	12	14	31	43	41	39	38	34	27	19	42	46	46	45	42	40	34	27	47	49	51	50	45	45	40	33	56
180	105	50	32	31	30	27	21	12	14	32	44	42	39	39	34	27	20	43	47	47	45	42	40	34	27	48	50	52	50	45	45	40	33	57
190	110	53	31	31	30	27	22	13	14	32	43	42	39	39	35	28	21	43	47	47	45	42	40	34	27	48	50	51	50	45	45	40	33	57
200	120	56	31	31	30	27	22	13	14	32	43	42	39	39	35	29	21	43	47	46	45	42	40	35	28	47	50	51	49	45	44	40	33	56
210	125	58	30	31	31	28	22	14	14	32	43	41	39	39	36	30	22	43	47	46	45	42	40	35	28	47	50	50	49	45	44	40	34	56
240	140	67	29	31	31	28	23	17	13	33	42	40	40	40	37	32	25	44	46	44	44	42	40	37	30	48	50	48	48	44	43	40	34	55

Ø8" (200 mm)		Differential Pressure DP in. w.g. (Pa)																																
Airflow		0.2 (50)					0.4 (100)					0.8 (150)					1.0 (200)																	
m <sup>3</sup> /h	CFM	L/s	125 Hz	250 Hz	500 Hz	1000 Hz	2000 Hz	4000 Hz	8000 Hz	Overall Lw (dB(A))	125 Hz	250 Hz	500 Hz	1000 Hz	2000 Hz	4000 Hz	8000 Hz	Overall Lw (dB(A))	125 Hz	250 Hz	500 Hz	1000 Hz	2000 Hz	4000 Hz	8000 Hz	Overall Lw (dB(A))								
225	132	63	29	27	24	23	18	11	13	27	39	39	36	33	31	26	18	39	43	42	41	39	37	32	24	44	46	45	46	44	42	38	29	49
250	147	70	30	28	26	24	19	12	13	29	41	40	37	35	33	26	19	40	44	43	42	40	38	32	24	45	47	47	45	44	42	37	28	49
275	162	76	31	30	27	26	20	13	13	30	42	41	38	38	34	27	20	42	46	45	42	41	38	32	24	45	49	48	45	44	42	36	27	49
300	177	83	32	32	29	27	21	14	14	31	44	41	39	40	36	28	21	44	47	46	42	42	39	32	23	46	50	50	45	44	42	35	26	49
325	191	90	34	33	30	29	23	16	14	33	45	42	40	41	37	30	23	44	48	47	44	43	40	34	26	48	51	51	48	45	44	38	28	51
350	206	97	36	34	31	31	25	18	15	35	46	43	40	42	37	31	25	45	49	48	46	44	42	36	28	49	52	53	52	47	46	40	31	53
400	235	111	39	37	34	35	28	21	17	38	48	45	42	43	39	34	28	47	51	51	50	47	45	40	32	53	55	57	59	50	50	44	36	58

Ø10" (250 mm)		Differential Pressure DP in. w.g. (Pa)																																
Airflow		0.2 (50)					0.4 (100)					0.8 (150)					1.0 (200)																	
m <sup>3</sup> /h	CFM	L/s	125 Hz	250 Hz	500 Hz	1000 Hz	2000 Hz	4000 Hz	8000 Hz	Overall Lw (dB(A))	125 Hz	250 Hz	500 Hz	1000 Hz	2000 Hz	4000 Hz	8000 Hz	Overall Lw (dB(A))	125 Hz	250 Hz	500 Hz	1000 Hz	2000 Hz	4000 Hz	8000 Hz	Overall Lw (dB(A))								
300	175	83	38	33	29	25	22	12	12	33	44	38	40	40	31	22	15	42	43	44	42	38	37	29	22	44	43	49	44	36	41	36	30	47
350	205	97	38	33	30	27	22	13	12	33	46	40	41	41	33	24	17	44	46	46	44	41	38	31	24	46	46	51	46	40	43	38	32	49
400	235	111	38	34	31	30	23	13	13	34	47	42	42	43	34	26	18	46	49	47	45	44	40	33	26	48	50	52	48	44	45	40	33	52
450	265	125	37	34	33	33	23	14	13	36	49	44	43	45	36	28	20	47	51	49	47	47	42	35	28	50	54	54	51	49	47	42	35	54
500	295	139	37	34	34	36	24	15	14	38	50	46	45	47	37	29	22	49	54	51	49	50	43	37	30	53	58	55	53	53	49	44	37	57
550	325	153	38	36	37	38	26	18	15	40	50	46	45	47	38	31	23	49	53	51	49	50	44	38	31	53	57	55	53	54	50	44	37	57
650	385	181	40	39	41	42	31	23	18	44	49	46	46	46	40	33	25	50	52	50	50	51	45	39	32	54	55	54	54	55	51	45	38	58

© 2015 American ALDES Ventilation Corporation. Reproduction or distribution, in whole or in part, of this document, in any form or by any means, without the express written consent of American ALDES Ventilation Corporation, is strictly prohibited. The information contained within this document is subject to change without prior written notice.